

CRYOTIGER®



BROOKS AUTOMATION

POLYCOLD® SYSTEMS

Operating Manual

CRYOTIGER® I Cooling System

Brooks Automation, Inc.
3800 Lakeville Highway
Petaluma, CA 94954
U.S.A.

Tel: 707-769-7000
Fax: 707-769-1380

Cool°Solutions®

© 2005 by Brooks Automation, Inc.
 All rights reserved.
 Printed in the United States of America

TRADEMARK RECOGNITION

Polycold® is a registered trademark of Brooks Automation, Inc.
 Cryotiger® is a registered trademark of Brooks Automation, Inc..
 AquaTrap® is a registered trademark of Brooks Automation, Inc..
Cool° Solutions® is a registered trademark of Brooks Automation, Inc.

Limited Warranty Terms

Polycold® Cooling Products, CryoTiger®, AquaTrap®, Polycold Compact Cooler, Repair Services and Certified Refurbished Products

Brooks Automation, Inc. cryogenic cooling products, including water vapor cryopumps (PFC, PCT, FLC, FI), chillers (PGC, PGCL), cryocoolers (P), CryoTiger, AquaTrap, Polycold Compact Cooler (PCC) and accessories, Certified Refurbished products (the “Products”) and Repair Service are warranted to be free from defects in materials and/or workmanship under normal service for the time period as set forth in Table A below from date of shipment from Brooks Automation, Inc Polycold Systems. (“Polycold”). The warranty for Repair Service is limited to the component parts replaced or repair performed by Polycold at Polycold’s facility. Customer is responsible for all charges and expenses for Polycold Services provided at Customer’s location by Polycold technicians as set forth in a quotation. Certified Refurbished Products and warranty exchange Products are remanufactured to like-new condition and contain used parts and materials. Except as provided for elsewhere herein, Products are intended for use on Large Stationary Equipment only, other end-use by customer may void this warranty.

Table A

Product	New Product Warranty	Repair Warranty	Certified Refurbished Cryogenic Cooling Products	Spare Parts & Accessories
Cryotiger® Products and Systems AquaTrap® Products and Systems Polycold® Compact Cooler (PCC)	15 Months	12 Months	N/A	12 months
Cryogenic cooling products, including: Water vapor cryopumps (PFC, PCT, FLC, FI), chillers (PGC, PGCL), cryocoolers (P), and accessories	24 Months	12 Months	12 months	12 months

POLYCOLD MAKES NO OTHER REPRESENTATIONS OR WARRANTIES, EXPRESS OR IMPLIED, WITH RESPECT TO PRODUCTS OR SERVICES. UNLESS EXPRESSLY IDENTIFIED AS A WARRANTY, SPECIFICATIONS IN ANY PRODUCT DATASHEET CONSTITUTE PERFORMANCE GOALS ONLY, AND NOT WARRANTIES. POLYCOLD MAKES NO WARRANTY RESPECTING THE MERCHANTABILITY OF PRODUCTS OR THEIR SUITABILITY OR FITNESS FOR ANY PARTICULAR PURPOSE OR USE, OR RESPECTING INFRINGEMENT OF INTELLECTUAL PROPERTY RIGHTS. POLYCOLD DISCLAIMS ANY WARRANTY WITH RESPECT TO PRODUCTS MODIFIED WITHOUT POLYCOLD’S WRITTEN CONSENT, REPAIRS MADE OUTSIDE OF OUR FACTORY, PRODUCTS RENDERED DEFECTIVE BY CUSTOMER MISUSE, NEGLIGENCE, CORROSIVE ATMOSPHERES, ATTACK BY FREE CHEMICALS WITHIN THE SYSTEM, ACCIDENT, DAMAGE BY CUSTOMER OR CUSTOMER’S AGENT, IS OPERATED CONTRARY TO OUR RECOMMENDATION, IF THE SERIAL NUMBER HAS BEEN ALTERED, DEFACED OR REMOVED, THE USE OF SERVICE REPLACEMENT REFRIGERANTS FROM ANY THIRD PARTY NOT LICENSED BY POLYCOLD, OR THE PRODUCT IS OTHERWISE COMPROMISED BY USE OF UNAUTHORIZED PARTS OR SERVICE, OR THE SYSTEM IS COMPROMISED BY CONTAMINATED GAS OR COMPONENTS, ALL AS DETERMINED BY POLYCOLD IN ITS SOLE DISCRETION.

IN NO EVENT WILL CUSTOMER BE ENTITLED TO, NOR WILL POLYCOLD BE LIABLE FOR INDIRECT, SPECIAL, INCIDENTAL, PUNITIVE OR CONSEQUENTIAL DAMAGES OF ANY NATURE, INCLUDING WITHOUT LIMITATION NEGLIGENCE, STRICT LIABILITY, OR OTHERWISE, ARISING AT ANY TIME, FROM ANY CAUSE WHATSOEVER, INCLUDING, WITHOUT LIMITATION, DOWN-TIME COSTS, DATA LOSS, DAMAGE TO ASSOCIATED EQUIPMENT, REMOVAL AND/OR REINSTALLATION COSTS, REPROCUREMENT COSTS, OR LOST PROFITS, EVEN IF POLYCOLD HAS BEEN ADVISED OF THE POSSIBILITY OF SUCH DAMAGES, AND EVEN IF THE LIMITED REMEDIES OF REPAIR OR REPLACEMENT FAIL OF THEIR ESSENTIAL PURPOSE. THIS WAIVER OF LIABILITY DOES NEITHER APPLY TO POLYCOLD’S LIABILITY UNDER A STATUTE, ACT OR LAW PERTAINING TO BODILY INJURY, NOR TO ANY LIABILITY INCURRING OUT OF DAMAGE TO THE BODY, HEALTH OR LIFE OF A PERSON.

The exclusive remedies for breach of warranty will be either repair or replacement of the nonconforming parts or Products during the warranty period at the sole discretion of Polycold, shipped ExWorks (Incoterms 2000) Polycold factory. Customer’s recovery from Polycold for any claim shall not exceed the amount paid by customer to Polycold for the Product or Service giving rise to such claim, irrespective of the nature of the claim, whether in contract, tort, warranty, or otherwise. Customer must inspect the Products within a reasonable time upon receipt, and must notify Polycold within 30 days of discovering a defect. Every claim on account of defective material or workmanship shall be deemed waived unless made in writing within the warranty period specified above. Polycold does not assume, or authorize any other person to assume, any other obligations or liabilities in connection with the sale of the Products.

All Polycold Products are subject to the Brooks Automation, Inc. General Terms and Conditions, an excerpt of which are set forth above.
 November 14, 2005

Table of Contents

1 SAFETY INFORMATION	1
1.1 Danger, Warning, Caution and Notes	1
1.2 Minimum Room Size Requirement	5
1.3 Symbols on the Equipment.....	5
2 INTRODUCTION	6
3 PRINCIPLES OF OPERATION.....	7
4 SPECIFICATIONS.....	11
4.1 System Components	11
4.2 Compressor	11
4.3 Cryocooler	14
4.4 Gas Lines	16
5 INSTALLATION.....	17
5.1 Unpacking, Inspection and Pressure Check.....	17
5.2 Position the Compressor	20
5.3 Install the Gas Lines	20
5.4 Install the Cryocooler.....	24
5.5 Evacuation and Leak Check.....	26
6 OPERATION	27
6.1 Starting the CRYOTIGER® I System	27
6.2 Stopping the CRYOTIGER® I System.....	29
6.3 Restarting the CRYOTIGER® I System after a Shutdown	29
7 PERIODIC INSPECTION & MAINTENANCE.....	30
7.1 Inspection	31
7.2 Maintenance	32
8 TROUBLESHOOTING	34
9 PARTS & SERVICE	37
9.1 Parts	37
9.2 Service.....	38

10 GLOSSARY	40
APPENDIX.....	42
A.1 Minimum Room Size Requirement	42
A.2 Compressor Electrical Schematic	43
A.3 Specifications for High Performance Cryocooler	44

List of Figures

Figure 1: Typical CRYOTIGER® I Compressor Front View	8
Figure 1a: Typical CRYOTIGER® I Cooling System.....	9
Figure 2: CRYOTIGER® I System Flow Diagram.....	10
Figure 3: Compressor Outline.....	12
Figure 4: Standard Cryocooler Outline	15
Figure 5a: Equalization (Charge) Pressure vs. Ambient Temperature.....	18
Figure 5b: Equalization Pressure vs Gas Line Length at Room Temperature	19
Figure 6: Attach Identification Label	21
Figure 7: Connect Gas Line to Compressor	23
Figure 7a: Connect Gas Line to Cryocooler.....	25
Figure 8: Typical Cooling Capacity Map	28
Figure 9: Male and Female Self-Sealing Couplings	32
Figure A1: Compressor Electrical Schematic.....	43
Figure A2: High Performance Cryocooler Outline Dimensions.....	45
Figure A3: High Performance Cryocooler Cooling Capacity Map	46

1 SAFETY INFORMATION

The CRYOTIGER® I Cooling Systems are designed to operate safely when the installation, operation, and servicing are performed in accordance with the instructions in this manual. Consult the nearest Brooks Automation Service Center with any questions you may have concerning the operation or maintenance of this equipment.

1.1 Danger, Warning, Caution and Notes

Four types of special notices — **DANGER**, **WARNING**, **CAUTION**, and **NOTE** are used in this manual. They are defined as follows and appear throughout the text.



DANGER indicates an imminently hazardous situation which, if not avoided, will result in death or serious injury.



WARNING indicates a potentially hazardous situation which, if not avoided, could result in death or serious injury.



CAUTION indicates a potentially hazardous situation which, if not avoided, may result in minor or moderate injury. Caution also is used to alert against unsafe practices and to alert personnel against equipment damage accidents.

NOTE

Notes give important, additional information, explanations or recommendations related to the appropriate procedure or discussion.

These special notices appear in the text where they are applicable.

1.1.1 DANGER



THE REFRIGERANT IS FLAMMABLE. Refer to MSDS product name Flammable HC Polycold® refrigerant.

FLAMMABLE GAS. AVOID IGNITION SOURCES. Liquid, flammable refrigerant collects in the cryocooler during operation. The gas lines or other components must never be disconnected until the cryocooler has been warmed to 10° to 30° C (50° to 86° F). Over-pressure will occur if the liquid is confined. Cold gas or liquid trapped in the cryocooler can reach high pressure as it warms and vent flammable gas through the cryocooler's pressure relief valve.

FLAMMABLE GAS. AVOID IGNITION SOURCES. Do not heat pressurized gas lines or other gas charged components. Prevent gas escape when connecting and disconnecting gas lines. Work in a ventilated area.

RISK OF FIRE OR EXPLOSION. Only trained personnel must repair components. Do not puncture the refrigerant tubing.

AVOID GAS LEAKS. Check the condition of the gasket seal on the male half of each gas coupling. Be sure the gasket seal is in place and the sealing surfaces on both the male and female halves are clean before connecting. Call a Brooks Automation Service Center if the seal is damaged. Keep the gas line couplings aligned when making or breaking a coupling connection. Leaks can occur due to the weight of the gas line or due to a sharp bend near the connection.

EXPLOSION HAZARD. Customer must provide a pressure relief valve on the vacuum vessel to prevent an over-pressure condition if a leak of high-pressure refrigerant occurs within the vacuum vessel. If the cryocooler is allowed to warm above operating temperature, the active pumping material in the system will release gas to increase the pressure in the vacuum vessel.

THE REFRIGERANT IS FLAMMABLE. Refer to Appendix A1 for minimum room size requirement.

1.1.2 WARNING

WARNING

AVOID INJURY AND EQUIPMENT DAMAGE. Operate this equipment as specified in the system manual.

AVOID ELECTRIC SHOCK. All electrical supply equipment must meet applicable codes and be installed by qualified personnel.

AVOID INJURY. Use two wrenches when connecting or disconnecting a gas line coupling to avoid loosening a bulkhead coupling. Gas pressure can project the coupling with enough force to cause injury.

PREVENT INJURY. Always wear eye protection when handling pressurized gas lines and other pressurized equipment.

EXTREME COLD HAZARD. Prevent frostbite. Do not touch any frosted parts.

AVOID ELECTRIC SHOCK. Disconnect the power to the compressor before troubleshooting the electrical components.

AVOID INJURY FROM BURNS. Allow the compressor to cool for 1/2 hour after shutdown before removing the cover for maintenance.

AVOID ELECTRIC SHOCK. Permit only qualified electrical technicians to open electrical enclosures, to perform electrical checks or to perform tests with the power supply connected and wiring exposed. Failure to observe this warning can result in injury or death.

FLAMMABLE GAS, COMBUSTION HAZARD, AVOID IGNITION SOURCES. Charge and purge the compressor with nitrogen to remove any residual, flammable refrigerant prior to unbrazing. Oil that is flammable may also be present in the gas lines. Use caution while unbrazing tubes.

AVOID ELECTRIC SHOCK. Touching a fully charged capacitor can cause severe electrical shock resulting in injury or death.

DAMAGE TO GAS LINES can result from crimping by repeated bending and repositioning.

1.1.3 CAUTION

CAUTION

PREVENT EQUIPMENT DAMAGE. De-pressurization and/or exposure to ambient conditions may cause contamination and equipment damage. Only service personnel trained by Polycold should perform this type of maintenance. This maintenance performed by unauthorized persons will void the warranty.

PREVENT EQUIPMENT FAILURE, CONTAMINATION OR A NUISANCE SHUTDOWN.

Do not tip the compressor more than 50 degrees from horizontal to avoid flowing oil into unwanted places. If the compressor is tipped more than 50 degrees, allow it to stand upright for at least four (4) hours before running, to permit any displaced oil to return to the compressor motor.

AVOID GAS LEAKS. Keep the gas line couplings aligned when making or breaking a coupling connection. Leaks can occur due to the weight of the gas line or due to a sharp bend near the connection.

MAINTAIN AMBIENT TEMPERATURE. Operating outside the specifications can damage the equipment.

PRESERVE YOUR WARRANTY. Modification to equipment without the consent of the manufacturer will void the warranty.

RISK OF FIRE OR EXPLOSION DUE TO PUNCTURE OF REFRIGERANT TUBING.

Follow handling instructions carefully.

PREVENT EQUIPMENT DAMAGE. Use trained personnel to install and remove the cryocooler and other system components.

PREVENT EQUIPMENT DAMAGE. PRESERVE YOUR WARRANTY. Operating the compressor without a cryocooler connected will reduce the life of the compressor and will void the warranty.

RISK OF FIRE OR EXPLOSION. Properly dispose of components in accordance with federal, state or local regulations.

PREVENT DAMAGE. Install the shipping covers to the cryocooler's cold tip and to the warm flange before shipping. Failure to protect the cryocooler will void the warranty.

1.2 Minimum Room Size Requirement

Due to the flammability of the refrigerant used in the CRYOTIGER System, there is a minimum room size requirement. Please see Appendix A1 for detailed information.

1.3 Symbols on the Equipment

Symbols on the equipment and their descriptions:



Caution: Risk of electric shock



Caution: Refer to accompanying documents



On

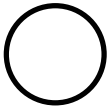

Off



Protective conductor (ground) terminal

2 INTRODUCTION

WARNING

AVOID INJURY AND EQUIPMENT DAMAGE. Failure to operate this equipment in the manner specified in this manual may create a hazardous condition resulting in damage to equipment and/or injury to the operators.

The CRYOTIGER® I Cooling System provides a cost effective means of obtaining and maintaining temperatures to as low as -203°C (70 K) without the need for replenishing or replacing any gas or liquid. It provides a temperature ranging from -203°C to 20°C with heat removal capacity ranging from 0.5 Watt to 30 Watt.

The system consists of the cryocooler, an air-cooled compressor and gas lines. The equipment, when properly maintained, is designed for continuous operation. Electricity to operate the compressor is the only utility required.

Two gas lines, supply and return, are used to link the cryocooler to the compressor. Self-sealing refrigerant couplings provide easy connection and disconnection.

The air-cooled compressor is designed to circulate gas refrigerant to the system.

The CRYOTIGER® I refrigerant is flammable and Brooks Automation proprietary.

U.S. Patent 5,337,572 and other pending U.S. and foreign patent applications cover this equipment. Unauthorized manufacture, sale or use of the apparatus or the refrigerant is strictly prohibited worldwide.

3 PRINCIPLES OF OPERATION

The CRYOTIGER® I Cooling System consists of basic modules: compressor, cryocooler and gas lines. See Figure 1 and Figure 1A.

The compressor continuously receives low-pressure refrigerant from the cryocooler through the system return gas line. It compresses, cools and cleans the gas, then delivers it through the system supply gas line to the cryocooler. See Figure 2.

When refrigerant gas leaves the compressor motor, it contains heat and compressor lubricant. Both must be reduced to acceptable levels before the refrigerant enters the cryocooler. From the compression space, the hot refrigerant with its entrained oil flows over the motor windings where the refrigerant loses some of its suspended oil. The refrigerant then flows through an air-cooled heat exchanger (after-cooler), where the refrigerant is cooled to ambient temperature. Next, the refrigerant passes through the oil separator and the filter-dryer for oil and moisture removal. From the filter-dryer, the high-pressure refrigerant is piped to the cryocooler. Supply and return refrigerant lines with self-sealing couplings allow for easy connection to the cryocooler and the compressor.

Oil is separated from the refrigerant in two stages. The first stage is by precipitation when the refrigerant passes over the motor windings. The second stage is the oil separator whose element collects oil mist from the refrigerant, agglomerates it, and returns the oil to the compressor.

Oil collected in the separator flows back to the compressor through a capillary tube. The differential refrigerant pressure across the system is the moving force, and the capillary size significantly limits the amount of refrigerant bypassed.

During compression of the refrigerant, the compressor motor housing and the oil absorb the heat produced. To remove this heat, cooling fins are attached to the compressor motor housing. Exhaust air from the after-cooler passes around the housing and fins, removing some of this heat. The after-cooler removes the remaining heat from the refrigerant.

The cryocooler receives high-pressure, room-temperature refrigerant from the compressor via the supply gas line. As the gas flows through the heat exchanger, the supply refrigerant is cooled by the refrigerant returning from the cold tip of the cryocooler, thus beginning the refrigerant condensation process. Before the refrigerant reaches the throttle device, it is mostly liquid and very close to the final refrigeration temperature. The throttle device allows the liquid to expand to a low pressure and enter the cold tip. The cold tip is the interface where the customer's heat load is absorbed by the refrigerant. The removal of heat causes some of the refrigerant to evaporate and raises the fluid temperature slightly. If an excessive heat load is applied to the cold tip, all of the refrigerant will evaporate and the temper-

ature will very quickly reach room temperature or even elevate to levels where permanent damage to equipment will result.

Through the system gas return line, low-pressure refrigerant from the cryocooler flows into the compressor.

Gas lines with self-sealing couplings allow for easy connection to and disconnection from the compressor and the cryocooler.

The pressure gauge on the rear panel of the compressor indicates return refrigerant pressure when the system is operating. The gauge indicates equalization (charge) pressure when the system is not running.

Pressure-relief valves inside the compressor housing and on the cryocooler prevent operation at an unsafe pressure.

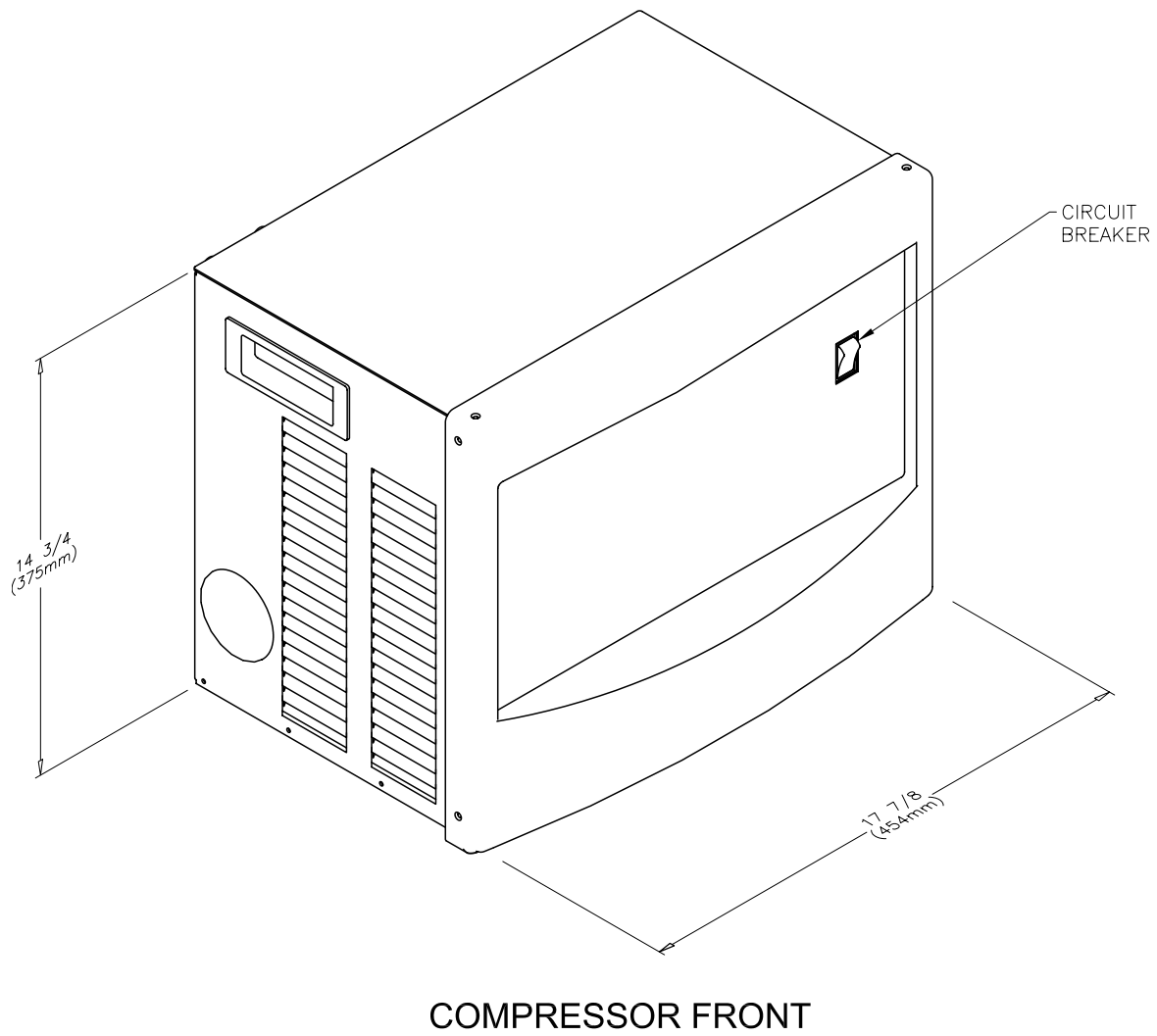

Figure 1: Typical CRYOTIGER® I Compressor Front View

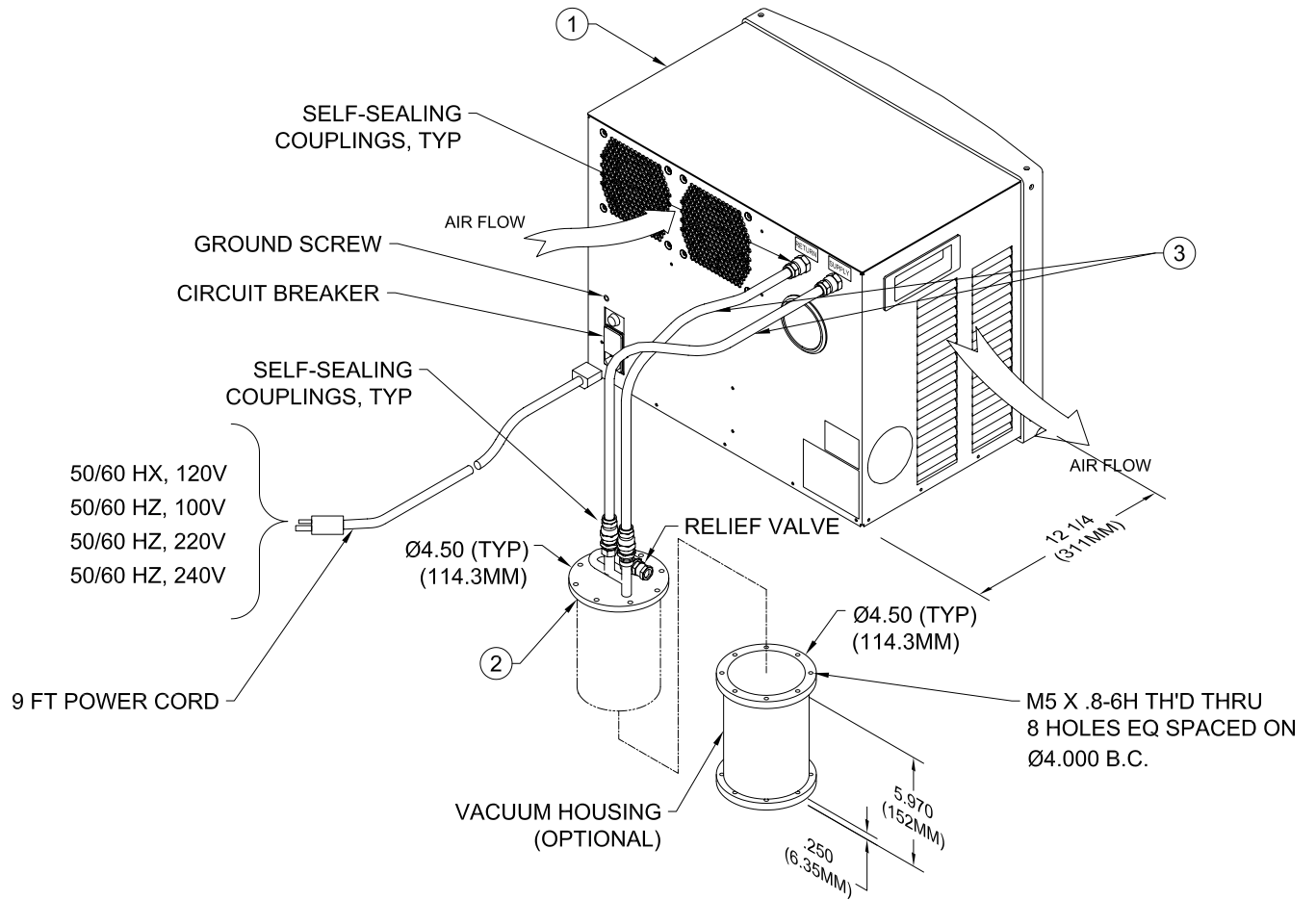

Figure 1A: Typical CRYOTIGER® I Cooling System

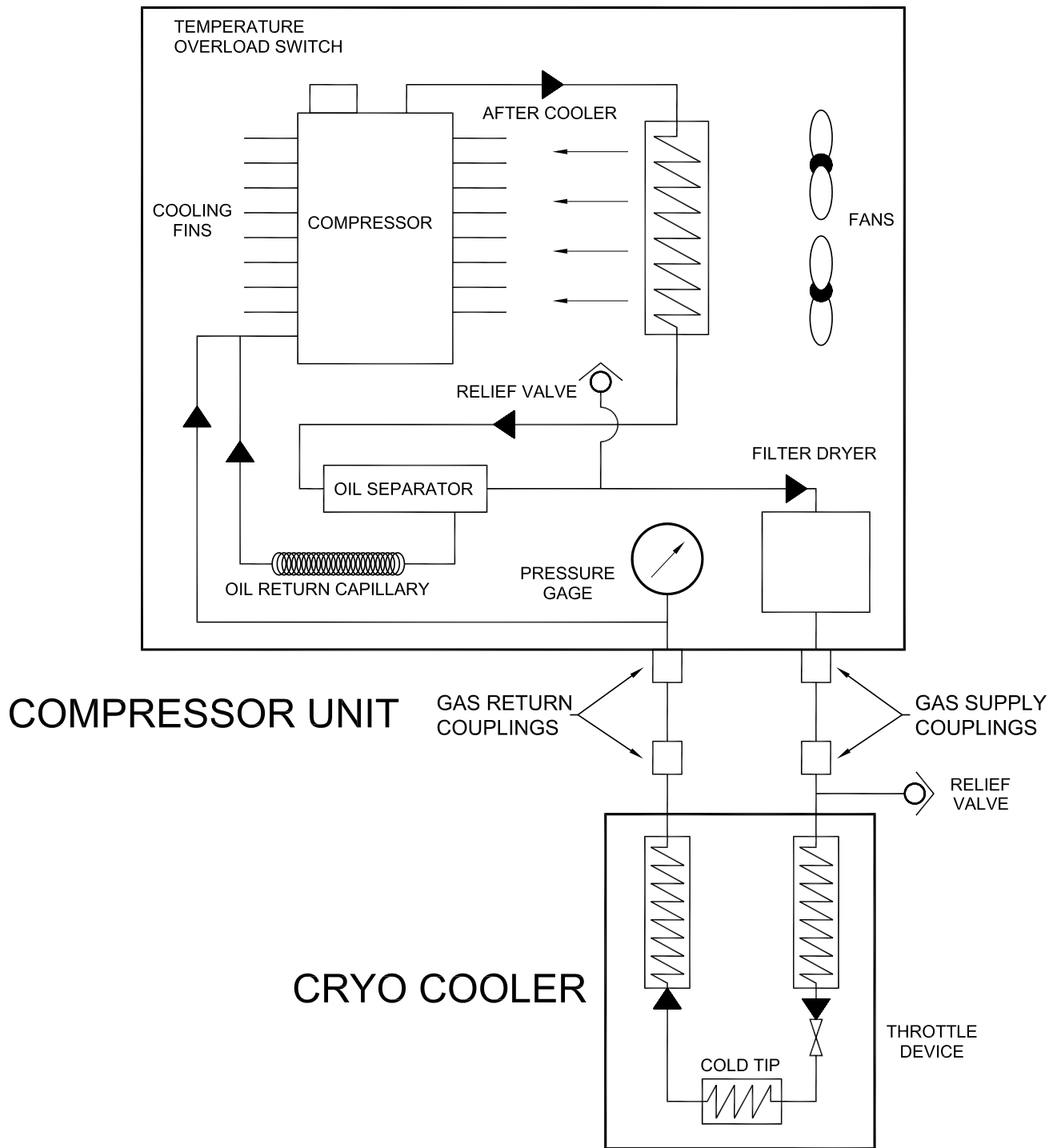

Figure 2: CRYOTIGER® I System Flow Diagram

4 SPECIFICATIONS

4.1 System Components

Figure 1A shows the major components of the system connected. A complete CRYOTIGER® I Cooling System, using standard components, consists of the following items. See section 9 Parts and Service for optional parts and accessories.

Item	Quantity	Description	Part Number
1	1	Compressor	T1102
2	1	Standard Cryocooler	T2114
Optional Parts			
3	2	Superflex Gas Line	T3102
4	2	Copper Gas Line	T3103
5	1	Filter/dryer Assembly (External Adsorber)	T4102

4.2 Compressor

Weights 32.2 kg (71 pounds)

Dimensions

454 mm (17 7/8") wide
 375 mm (14 3/4") high
 311 mm (12 1/4") deep

Color Codes

Gas couplings on the rear of the compressor and on the cryocooler are labeled SUPPLY (red) and RETURN (green). SUPPLY and RETURN labels are furnished for attaching to the gas lines by the customer.

Orientation

Compressor must be mounted base down and level within 10 degrees of horizontal.

NOTE

No temperature or vacuum sensing instrumentation is furnished by Helix Polycold Systems Inc.

Configuration

The air-cooled compressor is shown in Figure 3. Air enters the rear of the compressor enclosure and exits the left side. Gas lines and power cord connect to the rear of the enclosure.

Refrigerant

The compressor is charged with a FLAMMABLE, proprietary refrigerant.

Refrigerant Charge

43.5 to 54.8 grams (depends on gas type and charge pressure).

Ground Loops

A ground screw is located on the rear panel of the compressor. By design, this allows the entire system to share a common ground to prevent ground-loop interference.

Compressor Materials of Construction

Compressor Housing	Aluminum, Steel and ABS Plastic
Cooling Fins	Aluminum
Refrigerant Tubing	Copper and Stainless Steel
After-Cooler	Copper Tubes with Aluminum Fins
Oil Separator	Steel
Filter-Dryer	Copper

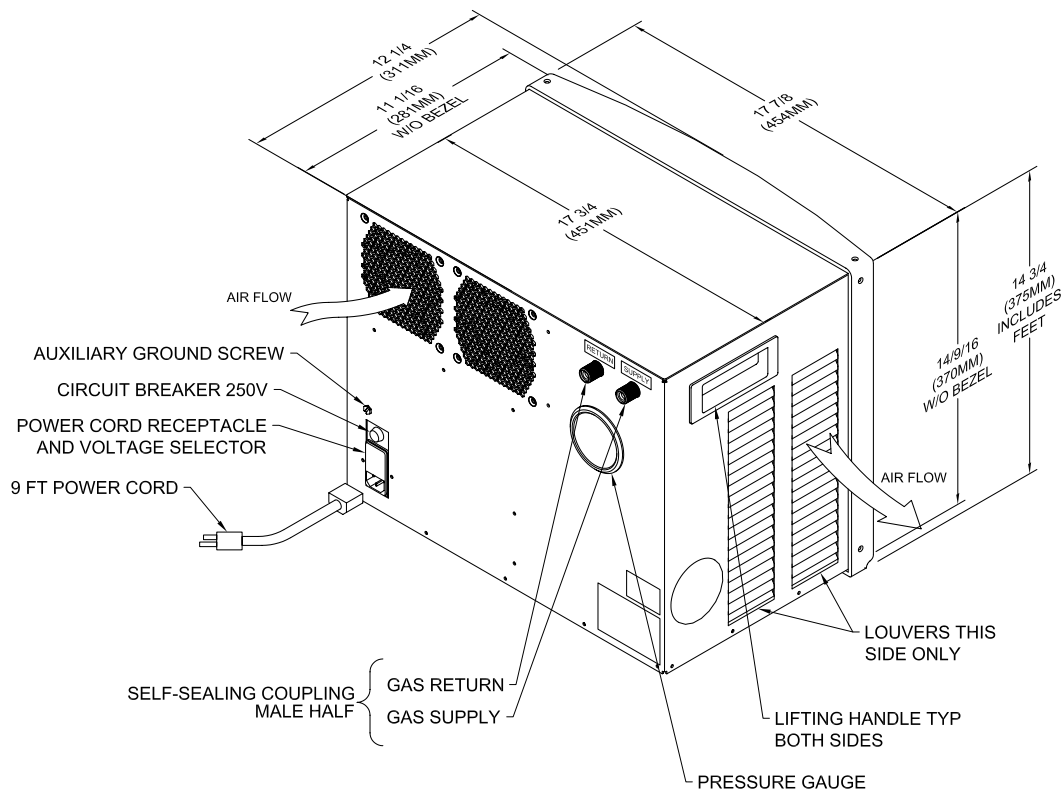

Figure 3: Compressor Outline

Heat Rejection

600 Watts nominal for cool down
 500 Watts nominal steady state
 800 Watts maximum.

Electrical Characteristics**NOTE**

Before operating the compressor, be sure the voltage selector is correctly set for the customer's electrical service voltage. Connect unit to a branch circuit with a certified 10,000 AIC rated circuit breaker. See the Installation section.

The compressor is considered "Ordinary" equipment, IP00 according to IEC 60529. The compressor is intended for installation in a Category II electrical environment.

For power supply of 60 Hz single-phase:

<u>Input Voltage</u>	<u>Voltage Selector</u>	<u>Full Load Current</u>
90 - 110 V	100 V	8 Amperes
108 - 132 V	120 V	7 Amperes
198 - 230 V	220 V	4 Amperes
225 - 264 V	240 V	4 Amperes

For power supply of 50 Hz single-phase:

<u>Input Voltage</u>	<u>Voltage Selector</u>	<u>Full Load Current</u>
90 - 105 V	100 V	8 Amperes
100 - 120 V	120 V	7 Amperes
190 - 220 V	220 V	4 Amperes
210 - 240 V	240 V	4 Amperes

Steady-state input power is 500 Watts.

Compressor motor ampere rating: 6 Amperes

Over current protection provided at machine supply terminals

Short-circuit interrupting capacity: 1500 Amperes

Fuse Rating: External fuses (located in power input module): 250 V, 1 A

Reset-type Circuit Breaker Rating (on electrical chassis): 250 V, 12 A.

Power Cord Connector: NEMA L5-15P (2 pole, 3 wire, 10 A) male plug to connect to customer's receptacle for 120 VAC service.

The switch breaker, rated at 10.0 amperes (12.5 trip amperes), on the front of the compressor is used to start and stop the compressor.

The compressor will restart automatically following a power interruption after power has been restored. If the circuit breaker trips due to an over current condition, reset the breaker to restart the compressor. A thermal overload (Klixon) switch provides additional protection.

System Gas Pressures

Equalization (charge) pressure: See Figure 5.

Typical steady state operating pressures (kPa is in absolute):

Supply	1830 - 2170 kPa (250 - 300 psig)
Return	101 - 310 kPa (0 - 30 psig)

Room Ambient Temperature

The air-cooled compressor can be operated under room temperature of 10° to 35° C (50° to 95° F). Maximum relative humidity is 80%.

Noise Level is 56 dBA, measured at a distance of 1 meter horizontal and 1.5 meters vertical from source.

Cleaning Instructions

There are no special cleaning requirements for the CryoTiger compressor. Clean only with water and mild detergents. Periodic cleaning of the interior for dust built-up may be performed by service personnel.

4.3 Cryocooler

Figure 4 shows the outline of the standard cryocooler.

NOTE

If this system uses a cryocooler different from the standard listed in these Specifications, see the Appendix for Specifications.

Cryocooler Materials of Construction

Cryocooler Housing	Stainless Steel
Self-Sealing Couplings	Zinc-Plated Steel
Heat Exchanger	Copper and Stainless Steel
Cold Tip	Copper
Support Tube	Stainless Steel
Insulation	Aluminized Mylar
O-ring, Cryocooler Flange	Viton
Relief Valve	Brass Body and Poppet, Steel Spring

Weight

1.5 kg (3.2 pounds)

Dimension

114.3 mm (4.50") diameter of mounting flange
 228.6 mm (9.0") long
 33.3 mm (1.312") diameter of cold tip

Refrigerant Charge

3.3 - 4.1 grams (depends on gas type and charge pressure)

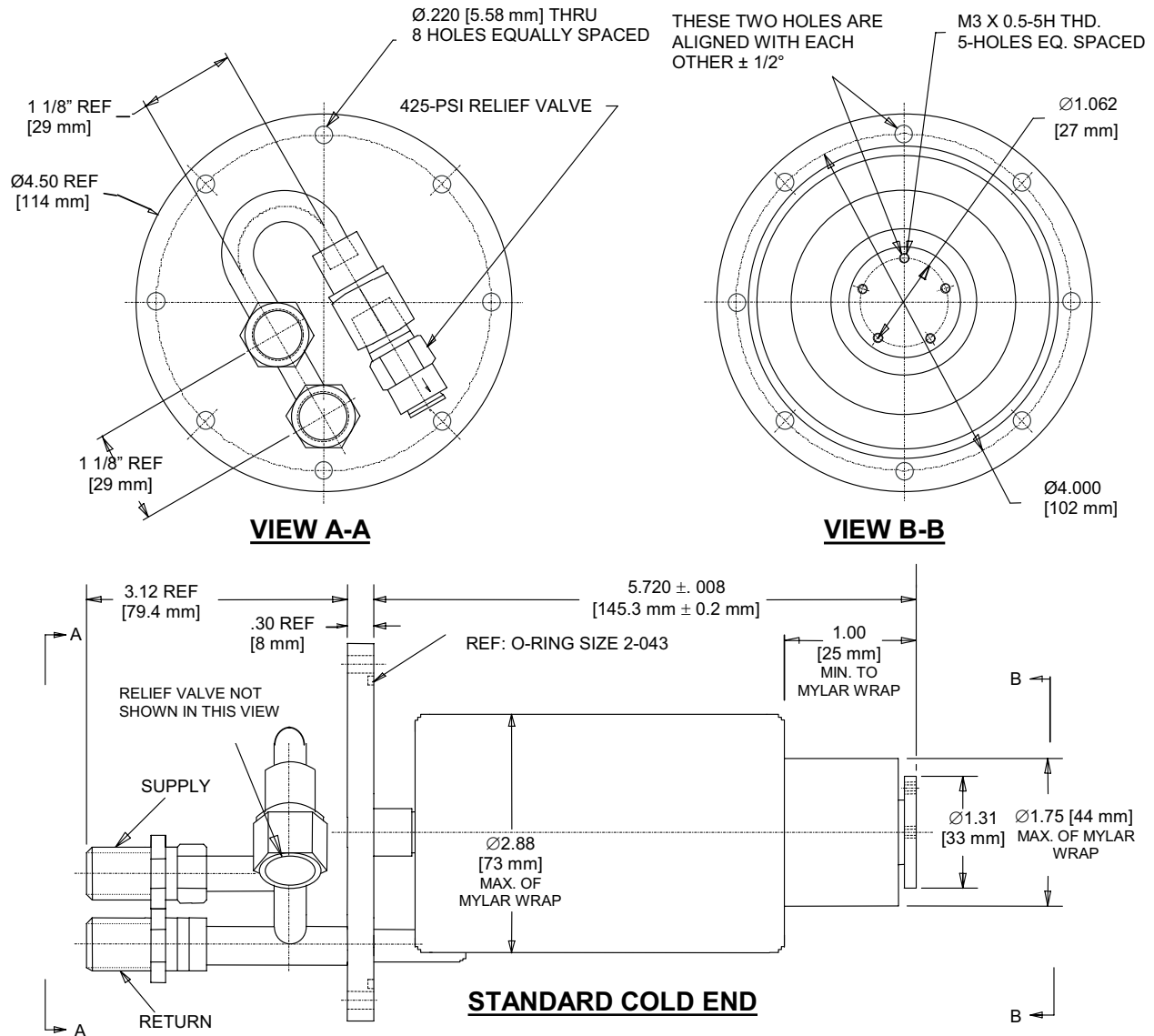

NOTES:

1. Maximum static loading of the cold tip at the interface is the summation of the following:
 Maximum force = 3.0 lbs. [1.36 kg].
 Maximum moment = 6 in. lbs [6.9 kg/cm].
2. Maximum static loading of the gas manifold at the interface is the summation of the following (both gas connections):
 Maximum force = 2 lbs. [0.91 kg].
 Maximum moment = 66 in. lbs. [76.16 kg/cm].
 This corresponds to a maximum unsupported length of 5 ft. of braided hose.
3. Materials of construction are stainless steel, copper, and brass. The gas couplings and relief valve contain elastomer seal material.
4. Recommended minimum inner diameter of customer supplied vacuum housing is 3.38 inches [85.85 mm].

Figure 4: Standard Cryocooler Outline

Refrigeration Capacity

The cryocooler provides a temperature ranging from 70 K (-203°C) to 293 K (20°C) with heat removal capacity ranging from 0.5 W to 30 W. Figure 8 shows the typical refrigeration capacity at 20°C (68°F). Available refrigeration capacity varies with gas type, system configuration, parasitic heat load, vacuum level and ambient temperature.

Temperature Stability at 20 °C (68 °F) ambient: ± 1.0 K at steady load.

Interface of the Cryocooler is a 114.3 mm (4.50”) diameter stainless-steel flange with a groove for customer’s elastomeric O-ring seal. Seal compression of the O-ring is achieved by attaching customer’s device to the cryocooler’s flange with eight (8) #10 cap screws, on a 101.6 mm (4”) bolt circle.

Power None required for cryocooler.

Orientation Cryocooler may be mounted in any position.

4.4 Gas Lines

Gas lines are constructed from Stainless Steel with Stainless Steel Braid or Copper. One each supply and return gas line connect the cryocooler to the remote compressor. Each gas line is terminated with size 4, female (4F), self-sealing couplings.

The weights of stainless steel gas line and refrigerant charge are listed below.

	Weight		Refrigerant Charge ⁽¹⁾
	(kg)	(pounds)	(grams)
Gas Line, 3.1 m (10 feet)	0.9*	2*	4 - 5*
Gas Line, 1.5 m (5 feet)	0.7*	1.5*	2 - 2.5*
Gas Line, 7.6 m (25 feet)	1.6*	3.5*	10 - 12.5*
Gas Line, 15.2 m (50 feet)	2.7*	6*	20 - 25*

⁽¹⁾ Refrigerant charge depends on gas type and charge pressure.

* One gas line.

5 INSTALLATION



THE REFRIGERANT IS FLAMMABLE. Refer to MSDS product name Flammable HC POLYCOLD refrigerant.



THE REFRIGERANT IS FLAMMABLE. Refer to Appendix A1 for minimum room size requirement.

Install the Compressor, Cryocooler, and Gas Lines according to the following procedures. It is important to follow the procedures in this manual step-by-step.

5.1 Unpacking, Inspection and Pressure Check

System components are shipped in two containers:

- Compressor and power cord.
- Cryocooler and gas lines (unless gas lines are ordered separately).

WARNING

PREVENT INJURY. Always wear eye protection when handling pressurized gas lines and other pressurized equipment.

CAUTION

AVOID EQUIPMENT FAILURE, CONTAMINATION OR A NUISANCE SHUT-DOWN. Do not tip the compressor more than 50 degrees from horizontal to avoid oil flowing into unwanted places. If the compressor is tipped more than 50 degrees, see section 5.1 step 2.

CAUTION

PREVENT DAMAGE. Install the plastic shipping cover on the cold tip and the warm flange before shipping. Also, install the compressor motor's shipping bolts before shipping. Failure to protect the cryocooler and the compressor will void the warranty.

1. Remove all components from their shipping containers and inspect them for damage. If there is physical damage to the compressor, contact the nearest Brooks Service Center.
2. If the indicator on the Tiltwatch® Plus shows a tilt angle between 50 to 70 degrees in ANY direction, wait AT LEAST 4 HOURS before beginning compressor installation. If the angle shown is less than 50 degrees, installation can proceed immediately. Please contact the Brooks Factory if this indicator is 80 to 180 degrees activated. Additional testing may be needed to ensure that the compressor will operate as specified.
3. Check the pressure gauge mounted on the back of the compressor. The pressure should be within the ranges shown on Figures 5a and 5b. If the equipment has recently been moved from an area where the temperature differs greatly from the present area, allow the components to equalize to the new room temperature before verifying correct charge pressure. If the pressure is not within the ranges, contact the nearest Brooks Service Center.

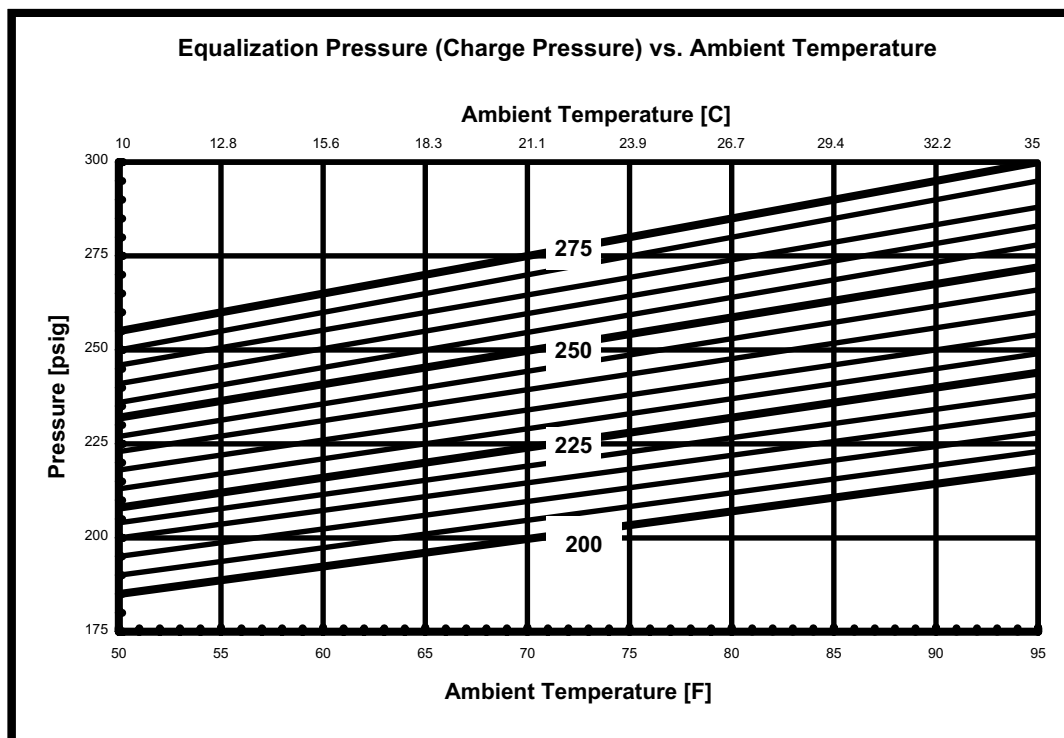

Figure 5a: Equalization (Charge) Pressure vs. Ambient Temperature

NOTE

Shipping bolts must be removed before operating the compressor. Retain the bolts and the shipping containers in reusable condition for returning the equipment to the factory.

4. Tilt the compressor not more than 50°. Using a 10 mm wrench, remove the three (3) hex head bolts (M6 x 22 mm long) from underneath the bottom panel of the compressor housing. Retain the bolts for re-use if the compressor will be shipped. Return the compressor to its operating position, within 10° of level.

NOTE

Refrigerant saturation temperature at system charge pressure is just below the freezing point of water. If the system is exposed to extreme cold during shipping, some of the refrigerant may condense. Depending upon the quantity of condensed refrigerant, it may take up to 48 hours at room temperature to recover the full system charge.

SYSTEMS WITH FLEXIBLE GAS LINES

Gas Line Length (Feet)	Gas Line Charge Pressure (psig)	Compressor Charge Pressure (psig)*	System Charge Pressure (psig)*
0 to 10	275	275	275
11 to 15	235	275	265
16 to 25	215	275	255
26 to 50	200	275	240

*Tolerance is +5 psig/-25 psig

SYSTEMS WITH COPPER GAS LINES

Gas Line Length (Feet)	Gas Line Charge Pressure (psig)	Compressor Charge Pressure (psig)*	System Charge Pressure (psig)*
0 to 25	275	275	275
26 to 40	250	275	270
41 to 60	225	275	260
61 to 85	210	275	250
86 to 120	200	275	240
121 to 150	190	275	235

*Tolerance is +5 psig/-25 psig

Figure 5b: Equalization Pressure vs Gas Line Length at Room Temperature

5.2 Position the Compressor

CAUTION

AVOID EQUIPMENT FAILURE, CONTAMINATION OR NUISANCE SHUTDOWN.

Do not tip the compressor more than 50 degrees from horizontal to avoid oil flowing into unwanted places. If the compressor is tipped more than 50 degrees, see section 5.1 step 2.

CAUTION

MAINTAIN AMBIENT TEMPERATURE. Operating outside the specifications can damage the equipment.

Place the compressor in a location that is protected from the elements and where the ambient temperature will always be within the range of 10° to 35° C (50° to 95° F).

It must be installed base down, within 10 degrees of horizontal, and preferably at a height convenient for making connections and reading the gauge.

Allow at least 160 mm (6") clearance from the rear and left side of the compressor for unrestricted flow of cooling air.

5.3 Install the Gas Lines

CAUTION

PREVENT EQUIPMENT DAMAGE. Support the weight of the gas lines while making the gas coupling connections at the compressor and at the cryocooler.

Tools required: one 16 mm (5/8") and two 19 mm (3/4") open-end wrenches.

Gas lines are shipped with protective dust plugs. Do not remove the plugs until the gas lines are ready to be attached. All bending and routing of gas lines should take place with plugs in place.

DANGER

FLAMMABLE GAS. AVOID IGNITION SOURCES. Do not heat gas lines or other components. Prevent gas escape when connecting and disconnecting the gas lines. Work in a well-ventilated area.

WARNING

PREVENT INJURY. Always wear eye protection when handling pressurized gas lines and other pressurized equipment.

WARNING

DAMAGE TO GAS LINES can result from crimping by repeated bending and repositioning.

CAUTION

RISK OF FIRE OR EXPLOSION DUE TO PUNCTURE OF REFRIGERANT TUBING. Follow handling instructions carefully.

1. SUPPLY (red) and RETURN (green) labels are furnished with the gas lines. Apply both RETURN labels to the same gas line by placing one at each end of the gas line in the location shown in Figure 6. Apply both SUPPLY labels to the other gas line using the same method. **DO NOT** apply different labels to the same gas line.

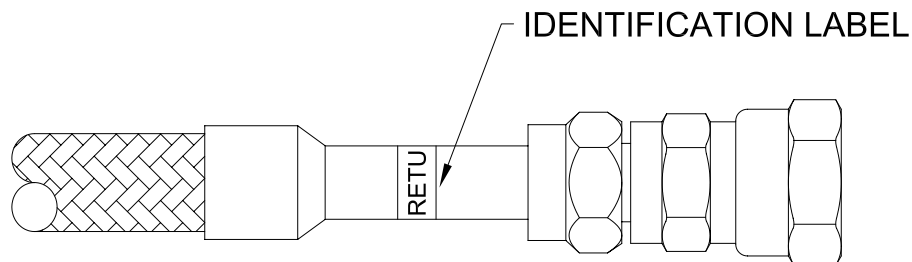

Figure 6: Attach Identification Label

NOTE

The cryocooler's gas manifold is designed to support a maximum unsupported length of 1.5 m (5 feet) of gas lines. Provide gas line supports so that the allowable unsupported length is not exceeded.

2. Arrange the system components so that the gas lines will be protected from stress and traffic. Observe the minimum bend radius of 102 mm (4") for flexible gas lines. Copper tubing can be bent to a 305 mm (12") radius without a tube bender and to a 15 mm (9/16") radius with a tube bender. Routing of gas lines must consider the need for gas line supports. See NOTE above.
3. Remove the dust plug from the compressor supply and return gas lines.
4. Remove the dust plug from the coupling on one end of each of the supply and return gas lines.

NOTE

Retain the dust caps and plugs to re-cover the couplings when they are not in use. They protect the couplings from damage and prevent entry of contaminants. Store the caps and plugs in a clean container.

NOTE

Verify that **ALL** couplings are free from dirt and debris. If any debris is found, wipe until clean, or use a solvent on a clean, lint-free cloth to remove the debris. Use only methanol, ethyl alcohol or denatured alcohol. Allow the solvent to fully evaporate before connecting the gas lines to the equipment. Verify that the male coupling has the gasket seal (Figure 10) installed in the body and the gasket seal is not damaged. Verify that the female coupling has no foreign matter from a male coupling.



FLAMMABLE GAS. AVOID IGNITION SOURCES. Do not heat gas lines or other components. Prevent gas escape when connecting or disconnecting gas lines. Work in a ventilated area.



AVOID INJURY. Use two wrenches when connecting and disconnecting gas lines to avoid loosening a bulkhead coupling. Gas pressure can project the coupling with enough force to cause injuries.



AVOID GAS LEAKS. Check the condition of the gasket seal on the male half of each gas coupling;. Be sure the gasket seal is not damaged and the sealing surfaces on both the male and the female halves are clean before connecting. Call a Polycold Service Center if the seal is damaged. Keep the gas line couplings aligned when making or breaking a coupling connection. Leaks can occur due to the weight of the gas line or due to a sharp bend near the connection.

5. Connect the SUPPLY gas line to the compressor's SUPPLY coupling. When tightening the connection, place a 19 mm (3/4") wrench on the freely-rotating part of the female coupling half (position "1" in Figure 7) on the gas line and a 16 mm (5/8") wrench on the base of the female coupling half (position "2") on the gas line. Hold the 16 mm (5/8") wrench steady, turn the first wrench clockwise to tighten the connection. **Torque all couplings to 8 to 10 N•m (6 to 8 lb•ft). (Use 14 to 16 N•m or 10 to 12 lb•ft if both the male half and female half are Aeroquip/Parker 5400 series couplings).** Fully tighten each coupling before proceeding to the next one.

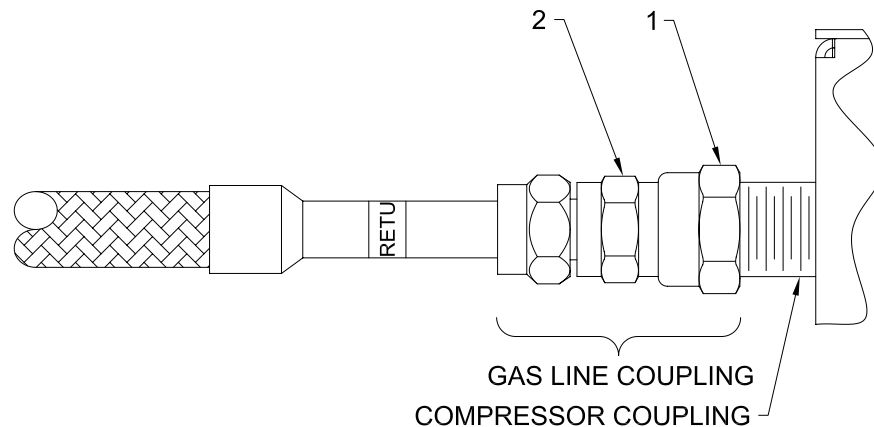

Figure 7: Connect Gas Line to Compressor

WARNING

DO NOT OVERTIGHTEN. Overtightening the couplings can damage the seal materials and result in gas leakage.

6. Connect the RETURN gas line to the compressor's RETURN coupling.

Installation of the gas lines will be completed after the cryocooler is installed.

5.4 Install the Cryocooler

Tools and Equipment required:

- one 16 mm (5/8") and two 19 mm (3/4") open-end wrenches.
- one medium Phillips screwdriver.
- one medium-tip flat screwdriver.
- one vacuum pump.



EXPLOSION HAZARD. Customer must provide a pressure relief valve on the vacuum vessel to prevent over-pressure if a leak of high-pressure refrigerant occurs within the vacuum vessel. If the cryocooler is allowed to warm above the operating temperature, any active pumping material being cooled by the cryocooler will release gas and increase the pressure within the vacuum vessel.

CAUTION

PREVENT EQUIPMENT DAMAGE. Use trained personnel to install and remove the cryocooler and other system components.

CAUTION

PREVENT EQUIPMENT DAMAGE. Install shipping covers to the cold tip and to the warm flange before shipping. Failure to protect the cryocooler will void the warranty.

1. Remove the shipping cover from the flange of the cryocooler by removing the #10 cap-screws and washers.
2. Mount the device requiring cooling to the cold tip using five M3 x 0.5 x 8 mm capscrews. Use either a gold or indium gasket to reduce thermal contact resistance. The standard cryocooler cold tip can support a maximum force of 3.0 lbs. with a maximum moment of 6 in. lbs.

3. Insert the cryocooler into the vacuum housing or similar vessel. Customer must maintain a minimum of 3.18 mm (0.125") clearance from the cryocooler's Mylar insulation. Customer must provide a pressure relief valve on the vacuum housing to prevent an over-pressure condition if a leak of the high-pressure refrigerant occurs within the vacuum housing. If active pumping material is attached to the cold tip and the cooler is allowed to warm above operating temperature, the material will desorb gas, causing an over-pressure condition in the vacuum housing.
4. Remove the gas coupling dust caps and verify that the couplings are free from dirt and debris. If any debris is found, wipe until clean, or use a solvent on a clean, lint-free cloth to remove the debris. (Use only methanol, ethyl alcohol or de-natured alcohol.) Allow the solvent to fully evaporate before connecting the gas lines to the equipment. Verify that the male coupling has the gasket seal (Figure 9) installed in the body and the gasket seal is not damaged.
5. Connect the SUPPLY and RETURN gas lines to the corresponding couplings. When tightening the connection, first place a 19 mm (3/4") wrench on the freely-rotating part of the female coupling half (position "1" in Figure 7A) on the gas line and a 16 mm (5/8") wrench on the base of the female coupling half (position "2") on the gas line. Hold the 16 mm (5/8") wrench and turn the 19 mm (3/4") wrench clockwise. At the very end, remove the 16 mm (5/8") wrench and place another 19 mm (3/4") wrench on the base of the male coupling half (position "3") and tighten the connection between the male half and female half until the torque specification is met. **Torque all couplings to 8 to 10 N•m (6 to 8 lb•ft). (Use 14 to 16 N•m or 10 to 12 lb•ft if both the male half and female half are Aeroquip/Parker 5400 series couplings).** Fully tighten each coupling before proceeding to the next one.

WARNING

DO NOT OVERTIGHTEN. Overtightening the couplings can damage the seal materials and result in gas leakage.

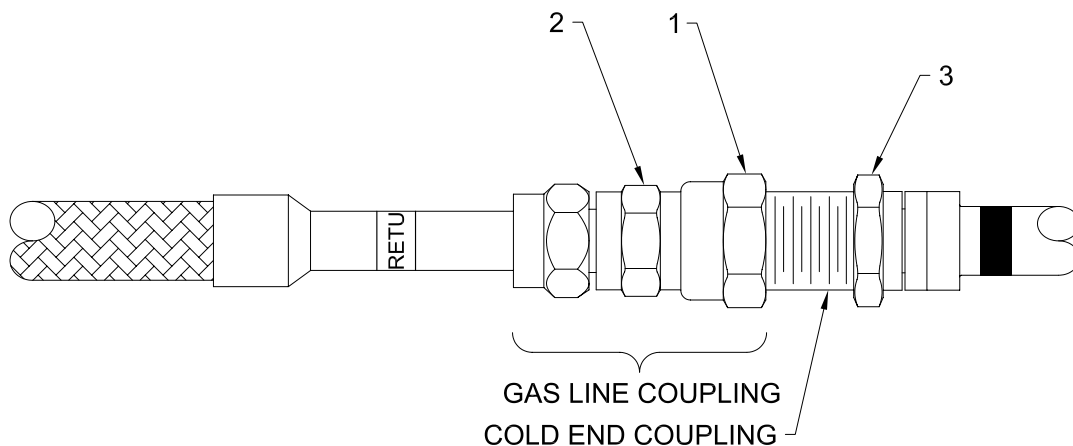

Figure 7A Connect Gas Line to Cryocooler

6. After all the components are connected, verify that the charge pressure is correct by checking the pressure gauge mounted on the back of the compressor. Account for ambient temperature by referring to Figure 5a.

NOTE

The compressor's gauge is for reference only.

This completes the installation of the cryocooler.

5.5 Evacuation and Leak Check

Customer must furnish and install a vacuum pump-out port. Using a vacuum pump, evacuate the enclosure and verify that the leak rate is at an acceptable level.

6 OPERATION

6.1 Starting the CRYOTIGER® I System

WARNING

AVOID ELECTRIC SHOCK. All electrical supply equipment must meet applicable codes and be installed by qualified personnel.

CAUTION

PREVENT EQUIPMENT DAMAGE. PRESERVE YOUR WARRANTY. Operating the compressor without a cryocooler connected will reduce the life of the compressor and will void the warranty.

1. Before starting the compressor, **pump the vacuum enclosure to 10^{-4} torr (0.1 micron of mercury) or less** to establish an insulating vacuum.
2. Read the pressure gauge. If the equalization pressure is within specifications (see Figures 5a and 5b), continue to either **2.1** or **2.2** for the installation procedure.

NOTE

Please read the Specifications section for voltage selection

2.1 For 120 VAC electrical service only: the voltage selector was set for 120 volts at the factory. Verify this by looking for “120” on the voltage selector adjacent to the power cord receptacle on the rear panel of the compressor. If not at “120” follow procedure in Step **2.2**.

2.2 To change the voltage selector for 100, 220 or 240 VAC electrical service: remove the power cord from the receptacle on the rear panel of the compressor. Using a 1/8”, flat-blade screwdriver, insert it in the narrow slot adjacent to the power cord receptacle to release the cover containing the fuse holder. Pull out the gray terminal block. Re-insert the block so that the correct voltage is visible. Snap the cover-fuse holder back in place. Verify that the correct line voltage is showing through the small window. Verify that the power cord is correctly rated for the selected voltage.

3. Connect the compressor's power cord to the receptacle on the rear of the compressor. Connect the other end of the cord to customer's power receptacle. Some installations may require equipment to be protected by emergency off (EMO) circuitry. If this is required, connect the power cord to the end user's system emergency off circuit.
4. Turn the compressor's switch breaker to the start position to turn the compressor on. Listen for any abnormal noise coming from within the compressor housing. This noise may be due to mishandling. Stop the compressor and notify the nearest Polycold Service Center if any problems are encountered.
5. Do not exceed the heat capacity of the cryocooler. Application of heat, which exceeds the stated capacity, will cause the liquid refrigerant at the cold tip to evaporate, resulting in overheating and possible damage to the equipment. See Figure 8, Typical Heat Capacity Load Map.

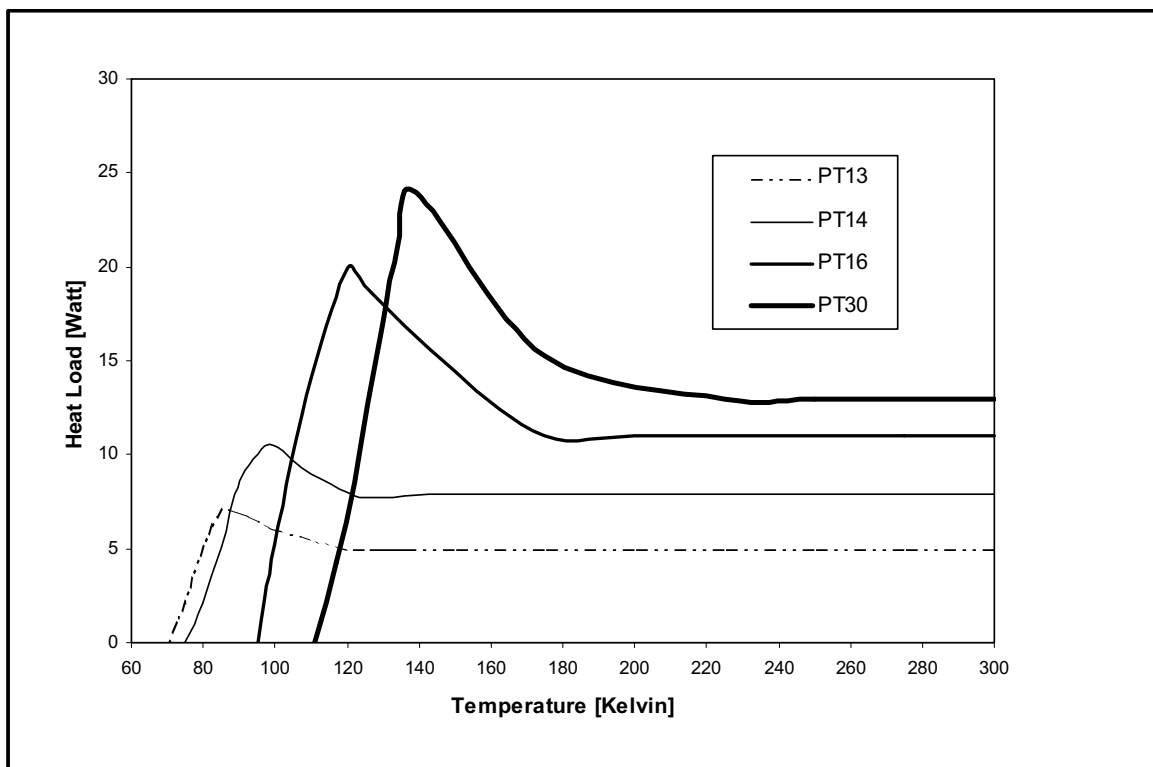

Map represents typical results and is for reference only. Individual results may vary.

Figure 8: Typical Cooling Capacity Map

6.2 Stopping the CRYOTIGER® I System



FLAMMABLE GAS. AVOID IGNITION SOURCES. Liquid, flammable refrigerant collects in the cryocooler during operation. The gas lines or other components must never be disconnected until the complete cryocooler has been warmed to 10° to 30° C (50° to 86° F). Over-pressure will occur if the liquid is confined. Cold gas or liquid trapped in the cryocooler can reach high pressures as it warms and vent flammable gas through the cryocooler's pressure relief valve.



EXTREME COLD HAZARD. PREVENT FROSTBITE. Do not touch any frosted parts.

Turn the switch breaker to the stop position to turn off the compressor.

6.3 Restarting the CRYOTIGER® I System after a Shutdown

If the compressor stops due to a power interruption, it is designed to restart after power has been restored. The compressor will stay off until the pressure has equalized on both the high and low pressure sides and until the compressor cools and the temperature switch closes, if opened. If the compressor stops for other reasons, refer to the Troubleshooting section.

A temperature switch on top of the compressor will open and stop the compressor or prevent it from starting if any of the following conditions exist:

- restricted air flow.
- compressor over current.
- compressor over temperature.

Be sure both fans are running and there are no cooling air restrictions.

If the compressor will not start after clearing the air vents and the heat exchanger, and the fans are running, see the Troubleshooting section. Allow time for the compressor to cool.

7 PERIODIC INSPECTION & MAINTENANCE

DANGER

THE REFRIGERANT IS FLAMMABLE. Refer to MSDS product name Flammable HC POLYCOLD® refrigerant.

DANGER

FLAMMABLE GAS. AVOID IGNITION SOURCES. Liquid, flammable refrigerant collects in the cryocooler during operation. The gas lines or other components must never be disconnected until the complete cryocooler has been warmed to 10° to 30° C (50° to 86°F). Over-pressure will occur if the liquid is confined. Cold gas or liquid trapped in the cryocooler can reach high pressures as it warms and vent flammable gas through the cryocooler's pressure-relief valve.

WARNING

AVOID INJURY FROM BURNS. Allow the compressor to cool for ½ hour after shutdown before removing the cover for maintenance.

CAUTION

PREVENT EQUIPMENT DAMAGE. Depressurization and/or exposure to ambient conditions may cause contamination and equipment damage. Only service personnel trained by Brooks Automation, Inc. should perform this type of maintenance. This maintenance performed by unauthorized persons will void the warranty.

CAUTION

PRESERVE YOUR WARRANTY. Modification to equipment or accessories will void the warranty.

CAUTION

RISK OF FIRE OR EXPLOSION. Properly dispose of components in accordance with federal, state and local regulations.

DANGER

RISK OF FIRE OR EXPLOSION. Only trained service personnel must repair components. Do not puncture refrigerant tubing.

7.1 Inspection

7.1.1 MONTHLY INSPECTION

Locate the compressor pressure gauge on the back panel. Record pressure. If the recorded values show a trend of decreasing, the cryotiger system may have a leak.

Record process temperature if applicable. If the recorded temperatures show a trend of warming up, it may indicate there is a leak in the cryotiger system.

7.1.2 INSPECTION AT SERVICE INTERVAL

Turn off the cryotiger system and wait 48 hours. Locate the compressor pressure gauge on the back panel. Record pressure. If the pressure (equalization pressure) has dropped more than 15 psig from last time, the cryotiger system may have a leak.

7.2 Maintenance

7.2.1 REFRIGERANT LEAKS

Research has shown that most refrigerant leaks occur at the self-sealing couplings and can be avoided if precautions are followed.

Coupling leaks may be caused by:

- dirt that accumulates on the coupling surfaces when connecting and disconnecting the gas lines.
- couplings that are not properly tightened according to the recommended torque specification.
- damaged metal parts or elastomer seals on either coupling which prevent proper mating or sealing.
- improper handling.

7.2.2 CLEAN THE COUPLING SURFACES

If the couplings are frequently disconnected, it may be necessary to inspect and clean both couplings.

Solvent required: denatured alcohol, methanol, or ethanol.

Clean any debris from the threads and the interface between the male half and female half with solvent on a lint-free cloth. Allow the solvent to fully evaporate before connecting the couplings.

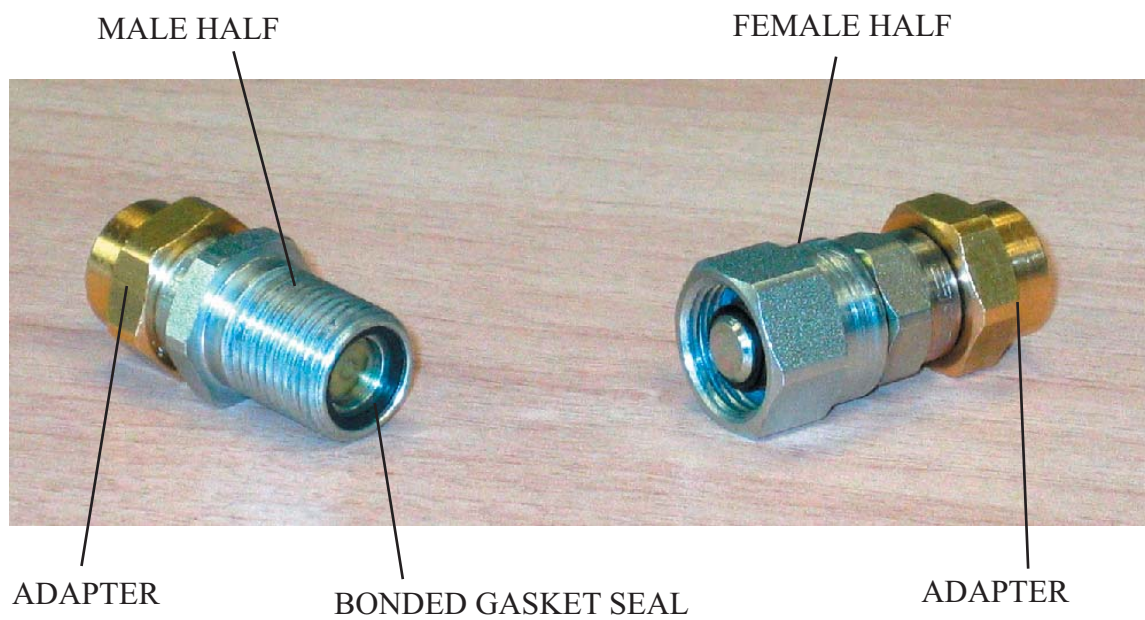

Figure 9: Male and Female Self-Sealing Couplings

7.2.3 CLEAN THE COMPRESSOR AIR PASSAGES

Periodically, as required by the ambient conditions, clean the inlet and outlet vents, heat exchanger fins and compressor fins.

This procedure will be necessary only if the compressor has accumulated significant dust on the inlet air grills, which is now causing reduced airflow to the motor. A significant reduction in airflow, depending on the ambient air temperature, will cause the thermal motor protector to shut down the compressor.

NOTE

When removing the panels from the compressor, retain the lockwashers. These lockwashers must be used when reinstalling the panels to maintain the electrical grounding path.

7.2.4 WASTE DISPOSAL

Discard any product, residue, disposable container or liner in an environmentally acceptable manner, in full compliance with federal, state and local regulations.

8 TROUBLESHOOTING

WARNING

ELECTRIC SHOCK. Permit only qualified electrical technicians to open electrical enclosures, to perform electrical checks, or to perform tests with the power supply connected and wiring exposed. Failure to observe this warning can result in injury or death.

WARNING

FLAMMABLE GAS. COMBUSTION HAZARD. AVOID IGNITION SOURCES. Charge and purge the compressor with nitrogen to remove any residual, flammable refrigerant prior to unbrazing. Oil that is flammable may also be present in the gas lines. Use caution while unbrazing tubes.

WARNING

ELECTRIC SHOCK. Disconnect the power to the compressor before troubleshooting the electrical components.

WARNING

ELECTRIC SHOCK. Touching a fully charged capacitor can cause severe electrical shock resulting in injury or death.

CAUTION

PRESERVE YOUR WARRANTY. Modification to equipment without the consent of the manufacturer will void the warranty.

The Troubleshooting Guide that follows lists problems which can occur with the system components and suggests causes and corrective actions.

<u>Problem</u>	<u>Possible Cause</u>	<u>Corrective Action</u>
Compressor does not start when the circuit breaker on the compressor is closed.	No electrical power, defective wiring, motor fault.	Check that the power source is on and the power cord is connected. Consult a Brooks Automation Service Center.
	12 A circuit breaker is tripped.	Push circuit breaker button to reset.
	Thermal overload switch is tripped.	Allow time for the compressor to cool and the switch to close.
Compressor does not start; no hum.	Wrong or defective wiring; open overload protector.	Check the wiring and fuses. Allow the compressor to cool, then restart.
Compressor starts but shuts down some time later.	Compressor is overheated; temperature switch opened; Incorrect wiring; motor fault; high equalization pressure; blown fuse.	Restricted airflow. Clean the after-cooler fins and air vents. Allow time for the compressor to cool and the switch to close. Verify that the compressor inlet and outlet air vents are spaced at least 160 mm (6") from another object. Check the wiring. Check the pressure. Consult a Brooks Automation Service Center.
		Fan (s) are not running. Check the fan circuit fuses located in the fuse holder part of the voltage selector. Replace the fuse if it is blown.
	Wrong voltage.	Recheck the voltage source. Recheck the voltage selector setting.
	Compressor component is blocked.	Consult a Brooks Automation Service Center.

<u>Problem</u>	<u>Possible Cause</u>	<u>Corrective Action</u>
Moisture on the cryocooler inlet and outlet manifold or on the upper vacuum enclosure. Otherwise, the cooler performance is normal.	High humidity in the room.	Lower the dew-point temperature or insulate the gas lines.
Moisture on the cryocooler upper vacuum enclosure. Degraded cooler performance.	Heat exchanger thermal short.	Return the cryocooler to a Brooks Automation Service Center for repairs.
Moisture on the lower vacuum enclosure.	Loss of vacuum.	Pump the vacuum enclosure to $< 10^{-4}$ torr.
Increased cool down time; cannot attain desired temperature; lack of capacity.	Low equalization gas pressure.	Consult a Brooks Automation Service Center.
	Loss of vacuum.	Check for vacuum leaks and repair. Pump to $< 10^{-4}$ torr.
Temperature cycles in the 250 to 275 K range.	Contamination is freezing in the system.	Consult a Brooks Automation Service Center.
Temperature is less than 200 K but higher than the normal operating range.	Vacuum leak.	Check the vacuum integrity. Pump the vacuum enclosure to $< 10^{-4}$ torr.
	Thermal short.	Verify that any attachment to the cold tip does not touch a warm surface.

9 PARTS & SERVICE

9.1 Parts

9.1.1 ORDERING

The nameplate fastened to the rear panel of the compressor identifies the compressor as follows:

Model number
Part number
Serial number.

Order parts by part name and part number.

9.1.2 PARTS IDENTIFICATION AND NUMBERS

Item	Part Name	Part Number
1	Gasket seal for male coupling	44636
2	Fuse, 5 x 20 mm, 1 A, 250 V, fan circuit (2)	34683
3	O-ring, Viton, cryocooler flange	77248
4	Capscrew, Phillips head, SS, M3 x 0.5 x 8 mm, for cryocooler cold tip	70779
5	Power cord, detachable	33641
Optional Parts		
6	O-ring, metal, cryocooler flange	77247
7	Adapter, 90°	262753A
8	Vacuum housing, 152 mm (5.970") long	262583B1
9	Weld flange, cryocooler	262624B
10	Gas line, Superflex, SS, 4F couplings, 1.5 m (5 feet)	T3102-005-x-yyy-xx
11	Gas line, Superflex, SS, 4F couplings, 3.1 m (10 feet)	T3102-010-x-yyy-xx

Item	Part Name	Part Number
12	Gas line, Superflex, SS, 4F couplings, 7.6 m (25 feet)	T3102-025-x-yyy-xx
13	Gas line, Superflex, SS, 4F couplings, 15.2 m (50 feet)	T3102-050-x-yyy-xx
14	Gas line, copper, 4F couplings, 1.5 m (5 feet)	T3103-005-x-yyy-xx
15	Gas line, copper, 4F couplings, 6.1 m (20 feet)	T3103-020-x-yyy-xx
16	Gas line, copper, 4F couplings, 18.3 m (60 feet)	T3103-060-x-yyy-xx
17	Gas line, copper, 4F couplings, 24.4 m (80 feet)	T3103-080-x-yyy-xx
18	CRYOTIGER® Service Kit for 110/115 VAC electrical service	264118A1
19	CRYOTIGER® Service Kit for 220/240 VAC electrical service	264118A2
20	Filter/dryer assembly (External Adsorber)	T4102

9.1.3 SUPPLIER NAME AND ADDRESS

Brooks Automation, Inc.
3800 Lakeville Highway
Petaluma, CA 94954
U.S.A.

Tel: 707-769-7000
Fax: 707-769-1380
E-mail: Sales@brooks.com

Supplier will make available on request circuit diagrams, component parts lists, description, calibration instructions or other information that will assist the user's appropriately qualified technical personnel to repair those parts of the equipment which are designated by the manufacturer as being repairable.

9.2 Service

For information on Incremental Gas Charge Procedure, please refer to Brooks Automation's procedure 270671A. For information on field service procedures, please refer to the CRYOTIGER® Field Service Manual, 264059A.

If it is determined that the whole system or some components need to be shipped back to the factory, please follow the procedures below to disconnect the systems and pack for shipping.

1. System temperature check. The coldest temperature of the system must be 10° C (50° F) or warmer before proceeding to next step.
2. Disconnect gas lines from the cold end (and external filter/dryer). Place a 19 mm (3/4") wrench on the base of the male coupling half (position "3" in

Figure 7A) and another 19 mm (3/4") wrench on the freely-rotating part of the female coupling half (position "1" in Figure 7A) and unscrew just enough to loosen the threaded connection between the male and female coupling halves. Then remove the wrench from the base of the male coupling half and place a 16 mm (5/8") wrench to the base of the female coupling half (position "2" in Figure 7A) and continue unscrewing the connection so that excessive twisting of the hose does not occur.

3. Disconnect gas lines from compressor. Use the same procedure described above.
4. Install shipping bolts to the compressor. Shipping bolts must be installed prior shipping to protect the compressor from damage due to excessive vibration during transportation.

HEADQUARTERS

Brooks Automation, Inc.
3800 Lakeville Highway
Petaluma, CA 94954
U.S.A.

Tel: 707-769-7000
Fax: 707-769-1380
E-mail: Sales@brooks.com

SERVICE CENTERS

Western U.S.A.

Brooks Automation, Inc.
3800 Lakeville Highway
Petaluma, CA 94954
U.S.A.

Tel: 707-769-7000
Fax: 707-769-1380

10 GLOSSARY

After Cooler: component in the refrigeration unit that removes heat from the refrigerant vapor after it exits the compressor

ASHRAE: American Society of Heating, Refrigerating and Air-Conditioning Engineers

AWG: American wire gauge

CE: European conformity

Cold End: the portion of refrigeration unit that is installed on a vacuum enclosure

Cold Tip: the portion of cold end that connect and cool the customers' object

Compressor: component in the refrigeration unit that raises the refrigerant pressure and causes the refrigerant to move through the circuit

Compressor Unit: the portion of the refrigeration unit that contains the compressor, after cooler, fans, oil separator and filter dryer

Copper Gas Line: refrigerant line that is made from copper

Cryocooler: the portion of refrigeration unit that is installed on a vacuum enclosure

EC: European conformity

EEC: European Economic Community

EMC: electromagnetic compatibility

EN: European norm (or standard)

Gas Lines: refrigerant lines between the compressor unit and cryocooler

IEC: International Electrotechnical Commission

MSDS: Material Safety Data Sheet

Manifold: service manifold gauge set

NEC: national electrical code

NPT: national pipe thread

PT-13: a proprietary mixture of refrigerants made by Brooks Automation, Inc.

PT-14: a proprietary mixture of refrigerants made by Brooks Automation, Inc.

PT-16: a proprietary mixture of refrigerants made by Brooks Automation, Inc.

PT-30: a proprietary mixture of refrigerants made by Brooks Automation, Inc.

Recharge: procedure for replacing the refrigerant in a refrigeration unit

Refrigerant Line: supply and return lines that carry refrigerant to and from the cryocooler

Return Line: the refrigerant line that carries refrigerant from the cryocooler to the compressor unit

Superflex Gas Line: flexible stainless steel refrigerant line

TÜV: Technical Supervision Society-verifies compliance with EN and IEC standards

UL: Underwriters Laboratories-verifies compliance with NEC standards

Voltage Selector: a device on compressor unit that allow user to select proper voltage according to available power supply

APPENDIX

A.1 Minimum Room Size Requirement (in m³)

A.1.1 CALCULATED ACCORDING TO ANSI/ASHRAE 15

1. System with flexible gas lines.

BLEND	Without External Adsorber				With External Adsorber			
	1.5 m (5')	3.1 m (10')	7.6 m (25')	15 m (50')	1.5 m (5')	3.1 m (10')	7.6 m (25')	15 m (50')
PT-13	3.8	4.1	4.7	5.7	6.8	7.1	7.7	8.7
PT-14	3.9	4.3	4.9	5.9	7.1	7.4	8.0	9.1
PT-16	4.7	5.1	5.8	7.0	8.4	8.8	9.5	10.8
PT-30	8.6	9.3	10.1	11.9	15.4	16.1	16.9	18.7

2. System with copper gas lines

BLEND	Without External Adsorber				With External Adsorber			
	3.1 m (10')	7.6 m (25')	15 m (50')	30 m (100')	3.1 m (10')	7.6 m (25')	15 m (50')	30 m (100')
PT-13	3.6	3.9	4.2	4.7	6.7	6.9	7.2	7.7
PT-14	3.8	4.1	4.3	4.9	6.9	7.2	7.5	8.1
PT-16	4.5	4.9	5.2	5.8	8.3	8.6	8.9	9.6
PT-30	8.3	8.9	9.2	10.1	15.1	15.7	16.0	16.9

A.1.2 CALCULATED ACCORDING TO EN 378

1. System with flexible gas lines

BLEND	Without External Adsorber				With External Adsorber			
	1.5 m (5')	3.1 m (10')	7.6 m (25')	15 m (50')	1.5 m (5')	3.1 m (10')	7.6 m (25')	15 m (50')
PT-13	5.9	6.4	7.3	8.9	10.6	11.1	12.0	13.7
PT-14	6.3	6.8	7.8	9.5	11.3	11.8	12.8	14.5
PT-16	7.0	7.6	8.6	10.5	12.6	13.1	14.2	16.0
PT-30	10.7	11.6	12.6	14.9	19.3	20.2	21.1	23.4

2. System with copper gas lines

BLEND	Without External Adsorber				With External Adsorber			
	3.1 m (10')	7.6 m (25')	15 m (50')	30 m (100')	3.1 m (10')	7.6 m (25')	15 m (50')	30 m (100')
PT-13	5.7	6.1	6.5	7.4	10.4	10.8	11.2	12.1
PT-14	6.1	6.5	6.9	7.8	11.1	11.5	11.9	12.8
PT-16	6.7	7.2	7.7	8.7	12.3	12.8	13.3	14.2
PT-30	10.3	11.1	11.4	12.6	18.9	19.6	20.0	21.2

A.2 Compressor Electrical Schematic

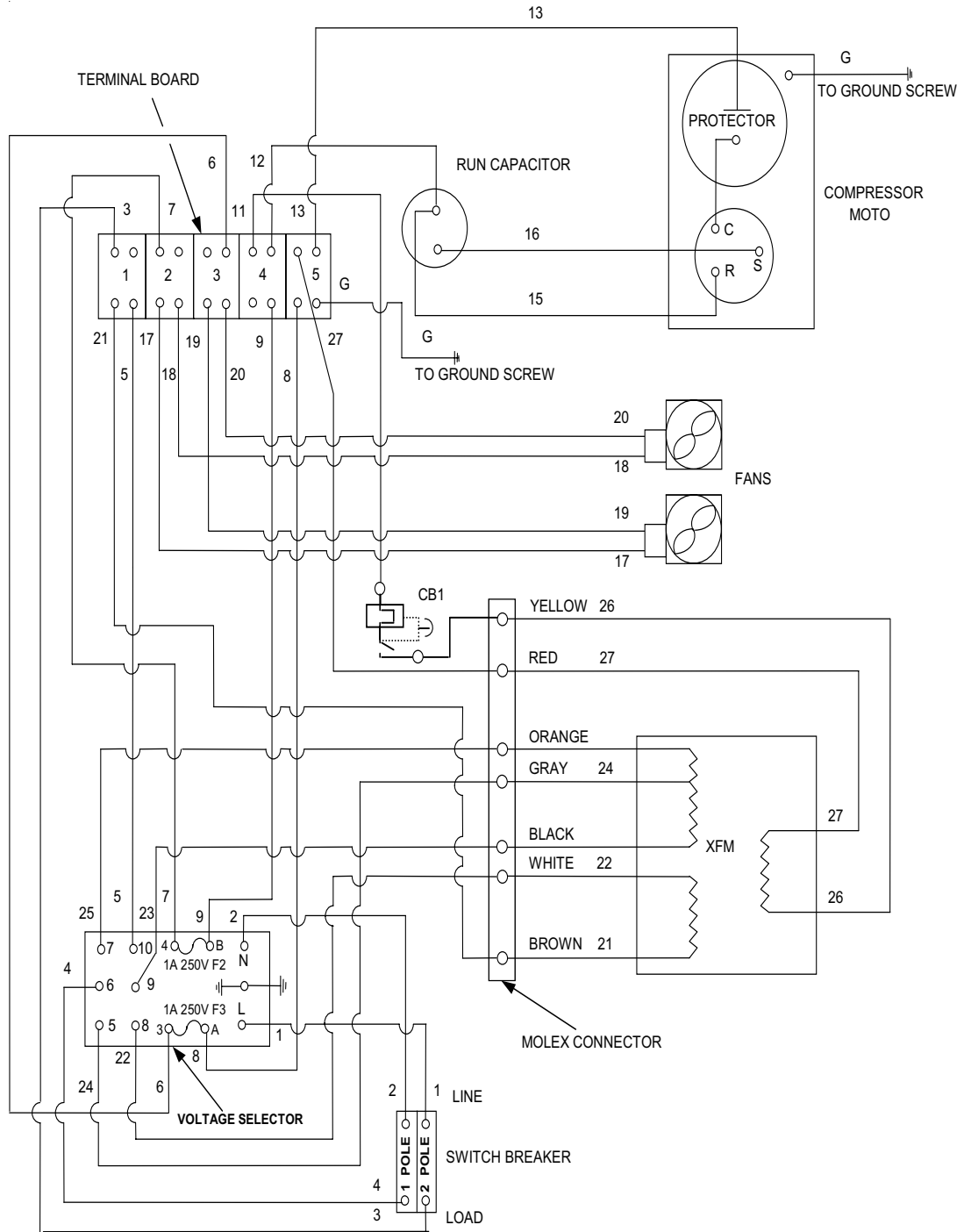

Figure A1: Compressor Electrical Schematic

A.3 Specifications for High Performance Cryocooler

Figure A2 shows the dimensions of the high performance cryocooler.

Cryocooler Materials of Construction

Cryocooler Housing	Stainless Steel
Self-Sealing Couplings	Zinc-Plated Steel
Heat Exchanger	Copper and Stainless Steel
Cold Tip	Copper
Filter Assembly	Brass and Stainless Steel
Support Tube	Stainless Steel
Insulation	Aluminized Mylar
O-ring, Cryocooler Flange	Viton
Relief Valve	Brass Body and Poppet, Steel Spring

Weight 1.8 kg (4.0 pounds)

Dimensions 114.3 mm (4.50") diameter of mounting flange
266.7 mm (10.5") long
33.3 mm (1.312") diameter of cold tip

Refrigerant Charge 3.0 - 4.1 grams (depends on gas type and charge pressure.)

Refrigeration Capacity at 20 °C (68 °F) ambient. See Figure A3, High Performance Cryocooler Heat Capacity Load Map with Different Refrigerants.

Available refrigeration capacity varies with gas type, system configuration, parasitic heat load, vacuum level and ambient temperature.

Temperature Stability at 20 °C (68 °F) ambient: ± 1.0 K at steady load.

Interface of the Cryocooler is a 114.3 mm (4.50") diameter stainless-steel flange with a groove for customer's elastomeric O-ring seal. Seal compression of the O-ring is achieved by attaching customer's device to the cryocooler's flange with eight (8) #10 cap screws, on a 101.6 mm (4") bolt circle.

Power None required for cryocooler.

Orientation Cryocooler may be mounted in any position.

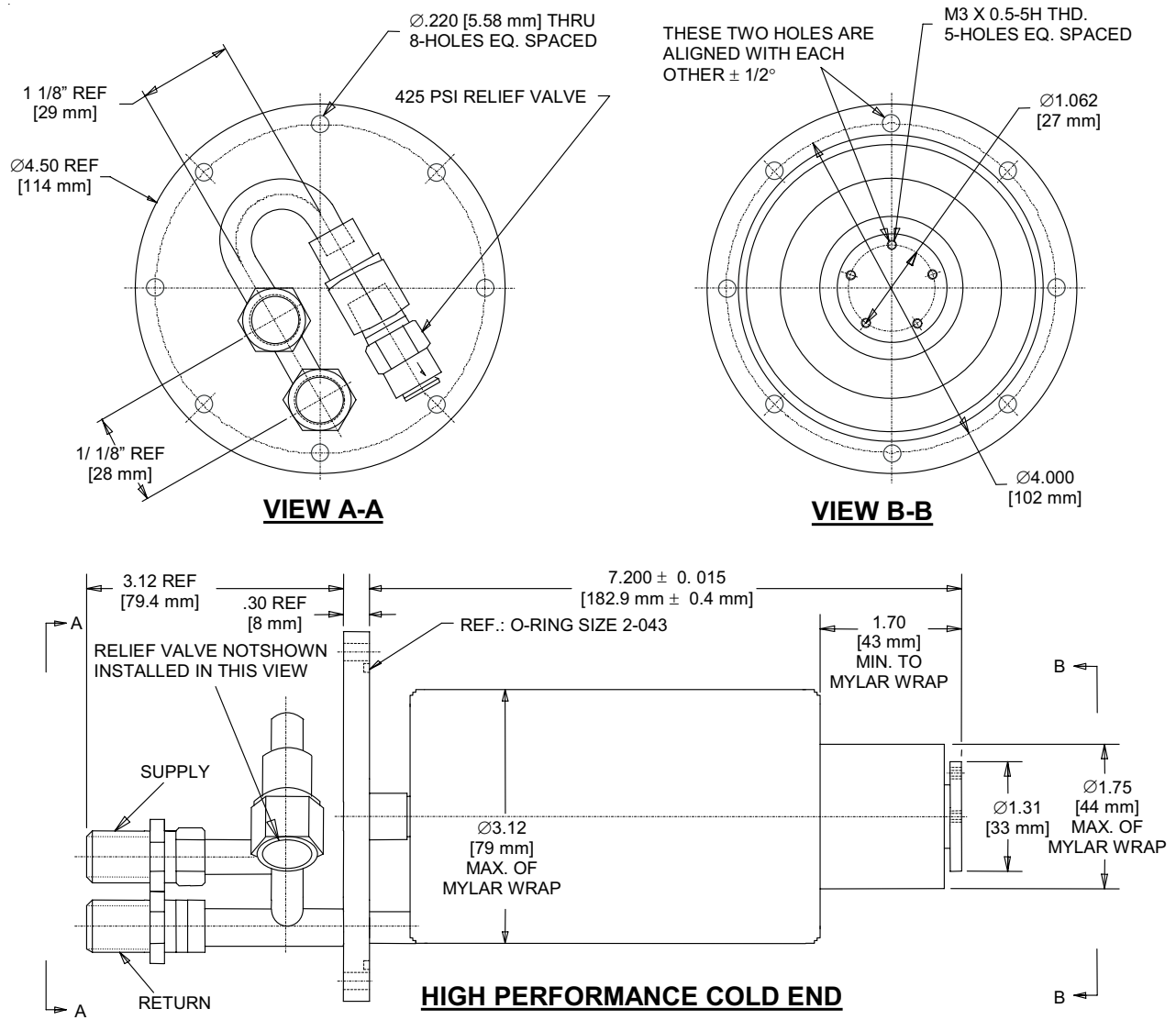

NOTES:

1. Maximum static loading of the cold tip at the interface is the summation of the following:
 Maximum force = 3.0 lbs. [1.36 kg].
 Maximum moment = 6 in. lbs [6.9 kg/cm].
2. Maximum static loading of the gas manifold at the interface is the summation of the following (both gas connections):
 Maximum force = 2 lbs. [0.91 kg].
 Maximum moment = 66 in. lbs. [76.16 kg/cm].
 This corresponds to a maximum unsupported length of 5 ft. of braided hose.
3. Materials of construction are stainless steel, copper, and brass. The gas couplings and relief valve contain elastomer seal material.
4. Recommended minimum inner diameter of customer supplied vacuum housing is 3.38 inches [85.85 mm].

Figure A2: High Performance Cryocooler Outline Dimensions

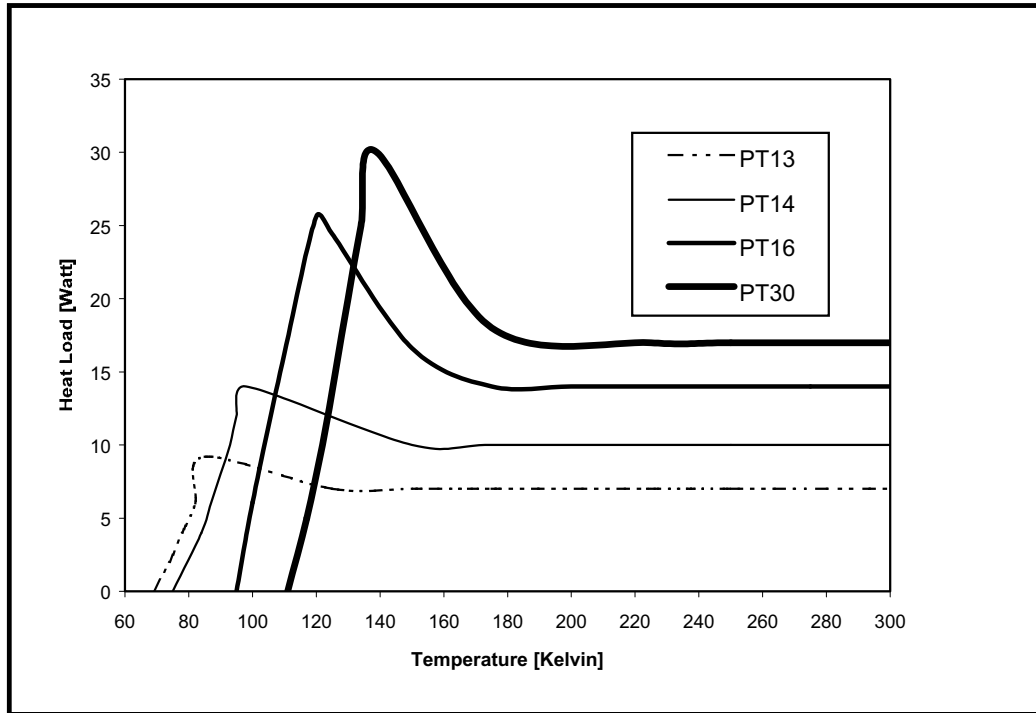

Map represents typical results and is for reference only. Individual results may vary.

Figure A3: High Performance Cryocooler Cooling Capacity Map